

# Precast Concrete Provides Function and Inspiration for Prince of Peace Church, Taylors, South Carolina



**Ronald E. Geyer, A.I.A.**

Architect  
Craig Gaulden & Davis, Inc.  
Greenville, South Carolina



**John Arrowood, P.E.**

Vice President  
Cary Engineering Consultants  
Greenville, South Carolina



**Jeffrey J. Hargett**

Director of Business Development  
Metromont Corporation  
Greenville, South Carolina



**Randall L. Davis, P.E.**

Precast Specialty Engineer  
Design/Build Engineers, Inc.  
Taylors, South Carolina

---

*In planning new worship facilities to serve increasing membership, a major issue facing contemporary churches is the challenge of balancing modern sensibilities with centuries-old church tradition. A Catholic parish serving the suburban community in Taylors, South Carolina, had outgrown the original church built in 1965. Lack of adequate space for the growing congregation eventually forced the parishioners to move into a gymnasium to celebrate mass. Approval of a design for a new, larger church was based on meeting the need of the Prince of Peace faith community for a structure built both on traditional liturgical practice and the possibilities of modern architecture. With its production quality, design flexibility, and dramatic aesthetics, a precast concrete solution surpassed alternative plans for steel and cast-in-place concrete structures. An arched and skewed precast concrete wall panel design incorporated both loadbearing structural capacity with a magnificent interior finish to create an inspirational space of worship.*

---

**A** Catholic parish serving a suburban community in northwestern South Carolina had outgrown its original church, built in 1965. Lack of space forced the congregation to celebrate mass in the less-than-ideal atmosphere of an adjacent gymnasium. In planning for a new, larger house of worship, the Prince of Peace faith community sought to recreate the centuries-old tradition of gothic architecture in a way that would speak to—and inspire—the present-day congregation (see Fig. 1).

Prince of Peace Church is situated in a residential suburb of Greenville, a city of nearly 400,000 people located about halfway between Atlanta, Geor-

gia, and Charlotte, North Carolina. In the 1970s, due to lack of an adequate space for worship, the initial membership of several hundred parishioners gathered for services in an eclectic mix of religious facilities—including an Episcopal and, later, a Lutheran Church (see Sidebar, “A Multi-Denominational Progression,” p. 37).

By 2000, the Prince of Peace congregation had grown to over 5000 parishioners, offered six services every weekend, and provided facilities for numerous parish, youth, and community services. As the original steel frame house of worship held seating for only 400 people, the need for a larger church became a pressing concern.

## HISTORIC STRUCTURE

The structural forms associated with traditional worship spaces have taken on symbolic meaning in the hundreds of years since first being introduced. Originally, however, medieval gothic arches and earlier predecessors were engineered responses to programmatic requirements for long spans and natural lighting.

On the Prince of Peace project, the use of precast concrete brought the same kind of graceful functionality to the structure in a way that cast-in-place concrete or steel could not. By rendering the finish appearance of contemporary stone left in its natural state, a precast concrete architectural finish al-



Fig. 1. From the vantage point of the choir loft, this photograph illustrates how precast concrete walls embrace and ennoble the worship space of the Prince of Peace Church and provide a sense of permanence and tradition for the present-day congregation. (Courtesy of Brian Dressler)

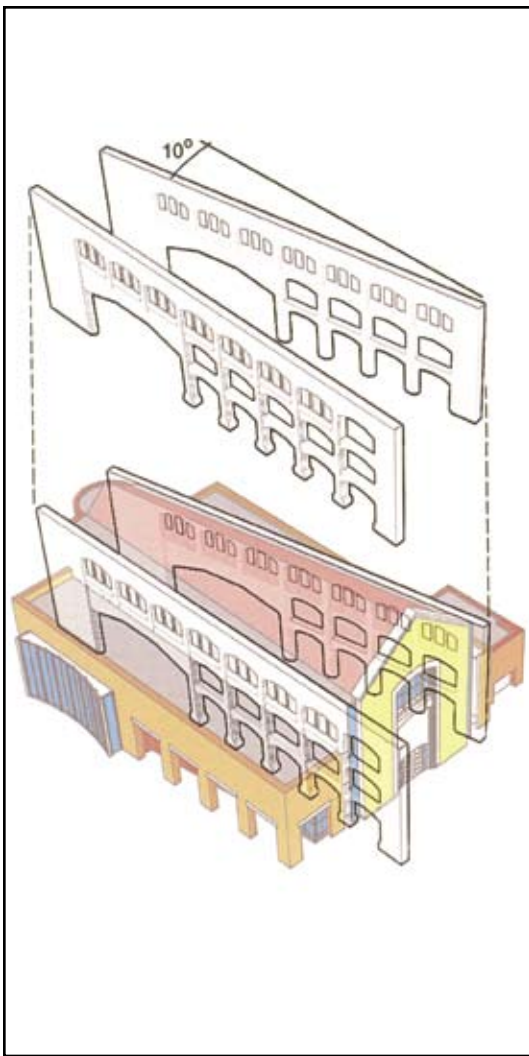

Fig. 2. Translation of the north wall off the grid forces the perspective, thus increasing the apparent height of the space, reinforcing processions that characterize Catholic liturgy, and serving acoustical requirements. (Courtesy of Craig Gaulden & Davis, Inc.)

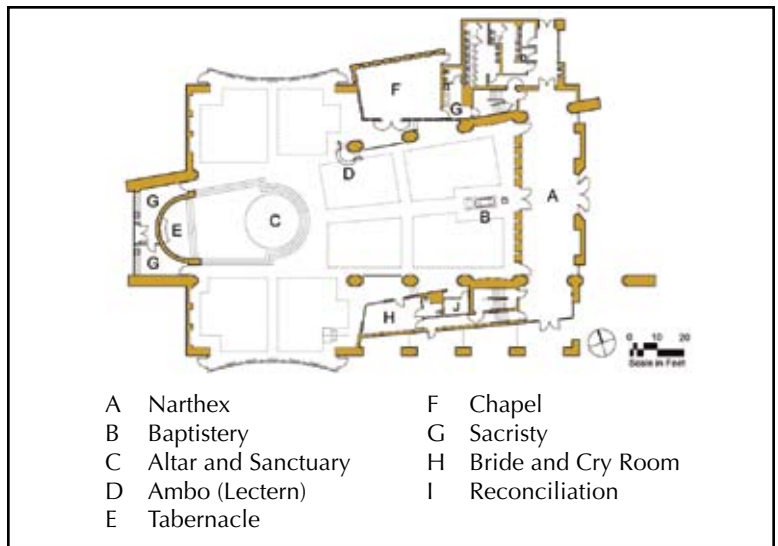

Fig. 3. Plan view of the Prince of Peace Church. (Courtesy of Craig Gaulden & Davis, Inc.)

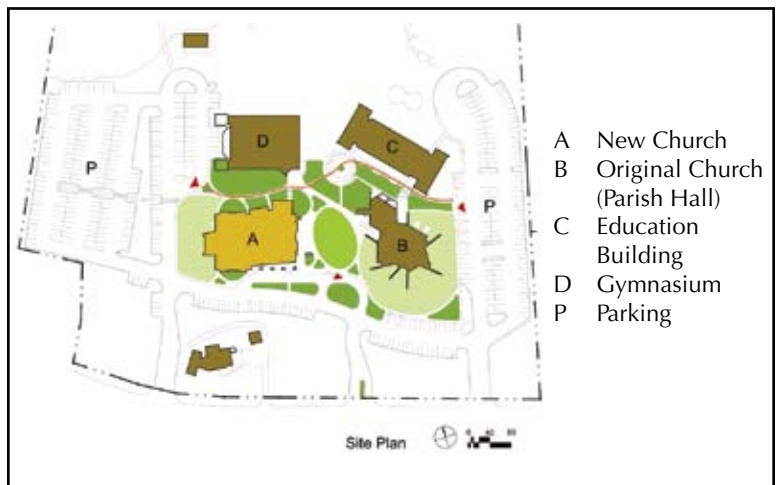

Fig. 4. The heart of the campus is marked by an elevated elliptical lawn, "protected" by an arm of the new church. (Courtesy of Craig Gaulden & Davis, Inc.)

Table 1. Precast components for the project.

Precast component	Plant location	Number of components	Maximum width, ft	Maximum length, ft	Maximum weight, lbs	Total area, sq ft	Finish
8 in. flat column cover	Charlotte	45	12	12	14,100	8,742	Sandblast with formliner
8 in. U-shaped column cover	Charlotte	69	10	10	10,000	7,860	Sandblasted
8 in. architectural spandrel	Charlotte	95	15	67	77,950	19,670	Sandblasted
18 x 36 in. rectangular beam	Greenville	1	—	25	16,848	—	Form
8 in. insulated wall panel	Greenville	28	3	30	6,750	2,520	Form/trowel
6 in. solid flat panel	Greenville	16	12	38	34,200	3,903	Form/trowel
Total number of components		254					
Total cu yd of precast concrete		972					

Note: 1 in. = 25.4 mm; 1 lb = 0.4536 kg; 1 sq ft = 0.0929 m<sup>2</sup>; 1 cu yd = 0.7646 m<sup>3</sup>.

lowed the church environs to take on symbolic importance—and, in essence, recreated an historic way of building.

In the preliminary planning stages, timber, steel, and cast-in-place concrete were considered as a building material for the new church. Eventually, however, these structural alternatives were eliminated in favor of a precast concrete solution. Over 250 precast concrete components were produced for the project, which included precast concrete panels, beams, and arched spandrels (see Table 1). Precast concrete wall panels provided both loadbearing structural capabilities and the desired architectural finish for the house of worship.

The total cost for the project was \$5.4 million, with the precast concrete portion of the budget being about \$1.1 million (see Table 2). Precast components consumed 972 cu yd (743 m<sup>3</sup>) of a total 1100 cu yd (840 m<sup>3</sup>) of concrete used in the construction of the new church.

Completed in September 2003, the new 25,000 sq ft (2320 m<sup>2</sup>) building houses a 1200-seat church, a 60-seat chapel, and ancillary support function spaces, such as the bridal room, baptistery, narthex (entrance portico), and sacristy (see Figs. 2 to 4). Through a series of public meetings, the architect documented the parishioners' priorities, testing them against requirements established by the Church. The architectural design needed to serve three major purposes: to provide encouragement and hope to the community of believers; to serve the liturgy; and to transform ordinary building materials and light in ways that reflect God's presence.

## INSPIRATIONAL DESIGN

The lofty goals of the owner, the Catholic Diocese of Charleston—to reflect God's presence and inspire the faith community with a structure's architecture—are probably the most challenging mandates a designer may encounter. A magnificent precast concrete design ultimately became the perfect marriage of form and function as the massive panels convey unmistakable strength and grace. But more than the capacity to fuse form and function, the precast concrete design captured the traditional blend of classic architecture



Fig. 5. Precast concrete arches emulate the traditional architecture of historic worship spaces and simultaneously create the modern aesthetic of natural stone. (Courtesy of Brian Dressler)

Table 2. Project timeline and costs.

Design phase, including master plan	September 1999 to April 2001
Construction phase	June 2001 to September 2003
Precast concrete erection	May 2001 to September 2002
Dedication of church	September 2003
Precast concrete cost	\$1.1 million
Total project cost	\$5.4 million

with the appeal of clean modern lines (see Figs. 5 and 6).

Meeting the owner's intangible goals required a creative and collaborated effort between all project team members. At first, the design progression for the nave walls began with a plan for precast concrete encasing steel columns. However, the architect, Craig Gauden & Davis, Inc., of Greenville, South Carolina, challenged representatives of the project precaster, Metromont Corporation, also of Greenville, to consid-

er whether a precast concrete structure that needed to *look* structurally significant, could *be* structurally significant in reality—that is, could precast concrete provide both the structural loadbearing elements as well as the desired architectural effects?

After the decision was made to build an all-precast concrete church, the project precaster, Metromont Corporation, met with the precast specialty engineer, Design/Build Engineers, Inc., of Taylors, South Carolina, and the

engineer of record, Cary Engineering Consultants, of Greenville, South Carolina. From then on, team collaboration began in earnest. Together with the assistance of Metromont's budgeting and design departments, the project team initially focused on the nave trusses, the lateral stability of the transept arch, the balcony framing, and connection between the steel roof trusses and the precast concrete elements.

The shift to a structural precast concrete design resulted in using an auger-



Fig. 6. Exterior photo reveals clean modern lines forged with classic forms. (Courtesy of Brian Dressler)

cast pile foundation system because the building was constructed over an old drainage swale. The transept arch support column dead load was approximately 500 kips (2200 kN).

The transept roof areas used conventional steel framing with slender tube columns within the curtain wall system. The steel trusses bearing on the precast concrete walls and the W16 × 36 steel roof purlins presented two of the more involved detailing issues of the project, as the precast concrete walls of the church were not parallel to each other—a configuration not encountered in typical construction (see Fig. 7).

Several important purposes were met by skewing the orientation of the walls in the design of the church (see Fig. 2). Translation of the north wall off the grid by 10 degrees forces the perspective, thus increasing the apparent height of the space, reinforcing processions that characterize Catholic liturgy, and serving acoustical requirements. Angled precast concrete walls embrace

the worship space and provide permanence, symbolizing the constancy and unchanging heart of the church. Surrounding spaces—transepts, chapel, and support spaces—respond to the church’s immediate surroundings, and are in many ways expected to change over time (see Figs. 3 and 4). The site design and building infrastructure allow future expansion for a new school facility (adjacent to the educational building and existing gymnasium) and additional church seating for up to 2,000 parishioners.

## FORM AND FUNCTION

The configuration of liturgical elements—like the ambo (lectern) and baptismary—is so traditional that it appears quite novel to most modern Catholics. In addition to its effect on the viewer’s perception of the space, the configuration of the long side walls reflects and reinforces the linear and rhythmic nature of processional rites,

such as the entrance of the celebrant for mass and confirmation and marriage ceremonies.

The dispersed placement of the baptismary, altar, and ambo allows and requires the movement of clergy around and among participants and imitates theological relationships (see Fig. 8). This architectural support for the intrinsic interaction and sense of community between clergy and laity meets the goals of the parish by serving its liturgical purpose.

Churches are primarily places where—according to religious precept—the people of God gather and are “made one...and are the church, the temple of God built with living stones.” Consequently, the layout of the church proper and its environs serve to encourage interaction and a sense of unity and also to prepare participants to enter into the liturgy.

The layout design of the Prince of Peace facilities helps to create the desired ambience for worship. The



Fig. 7. Steel roof trusses bearing on precast concrete walls required careful attention to detail, as the precast concrete walls were not parallel. (Courtesy of Design/Build Engineers, Inc.)



Fig. 8. The altar and sanctuary are visible from all seating areas during the Prince of Peace dedication ceremony, September 2003. (Courtesy of Pietro Smith)

heart of the campus is marked by an elevated elliptical lawn, “protected” by an arm of the new church (see Fig. 4). The placement of the new church organizes existing buildings along a landscaped interior walk, offering communicants a preparatory environment distinct from the street and parking areas (see Fig. 9). Inside, the shape of side aisles allows participants a full view of one another, with long, clear lines of sight from nave to transept.

In recent decades, many Catholic parishes in this country have responded to a desire to communicate relevance by abandoning symbols of historic roots and opting instead for novel modernistic designs. However, it is precisely the appeal of the church’s long-held traditions and constancy that draw many to this faith. In contrast, the Prince of Peace project relied on a creative and well-designed precast concrete solution to reconcile these seemingly com-

peting perceptions of the “old” and the “new” church.

## PRODUCTION

The first precast concrete panels were erected on January 8, 2002 (see Fig. 10), and erection was completed on March 27, 2002, based on a precast production schedule of 51 days. Precast production took place at two of Metromont’s facilities—one in Charlotte, North Carolina, and the other in Greenville, South Carolina.

The building’s central core consists of a loadbearing precast concrete frame that features 65 ft (20 m) long arched spandrels, each weighing more than 77,000 lbs (35000 kg) (see Figs. 11 and 12). Although the configuration of the long arched sidewalls presented numerous connection challenges, the project architect emphasized that the skewed walls were critical to reinforcing processional ceremonies at the church. Stair-stepped column covers (see Fig. 13) provided a distinctive, old-world feel. Finishes included sandblasting, form-liner, and steel-troweled treatments for the precast concrete spandrels, column covers, and wall panels.

Six different precast components are featured in the project, in a wide variety of shapes and sizes (see Table 1). These components include 8 in. (203 mm) thick architectural spandrels, 8 in. (203 mm) thick U-shaped architectural column covers, and 8 in. (203 mm) thick flat architectural column covers. Also included were 18 × 36 in. (457 × 914 mm) structural rectangular beams, 8 in. (203 mm) thick insulated structural wall panels, and 8 in. (203 mm) thick solid structural wall panels (see Figs. 14 to 17). The mix design for the precast concrete was normal weight gray 5000 psi (35 MPa) concrete, and was selected to provide an old, established touch.

## PRECAST ADVANTAGES

Designers originally considered other structural systems, such as cast-in-place concrete and structural steel framing, but a precast concrete solution was chosen for its high quality and its ability to support the tight sequencing requirements. Original design concepts included steel columns wrapped with



Fig. 9. A landscaped interior walkway offers communicants a preparatory environment distinct from street and parking areas. Note the original 1965 steel-frame structure in the background to the left. (Courtesy of Brian Dressler)

non-loadbearing precast column covers. This design was modified to make the precast column covers loadbearing, thus providing savings to the owner by forgoing the cost of steel columns.

Precast concrete walls were further used for the central 120 ft (36.6 m) nave area and other architectural and structural elements of the facility. The detail and finish of the exposed architectural precast concrete achieved all the owner's aesthetic goals, in particular, by lending a grand sense of strength and permanence to the church.

Precast concrete provided architectural finishes that notably complement the other building materials, such as brick surfaces, painted steel and dry-wall, and stained trim work. The precast concrete columns, in particular, blend very well with the salt-finished concrete and slate floors (see Fig. 18).

Another advantage in using loadbearing precast elements was to further minimize structural redundancy.

With precast loadbearing components also serving as the finished surface, the owner was able to save monies that would have been required for surface treatments if a structural steel or cast-in-place system were used. Savings resulted by taking advantage of the multi-function attributes of a precast concrete system and its inherent production economies over alternative solutions that would require more costly and labor-intensive finishes after the structural elements were in place. Overall, the precast concrete system offered more economic and aesthetic advantages by providing the best of both worlds—structural elements and architectural surfaces—in one material.

Large, elaborate custom molds had to be individually built for all of the architectural pieces (see Fig. 16). This included the loadbearing arched spandrels, which featured 56 ft (17 m) long sweeping arches with 70 ft (21 m) radii, and included buildouts and bull-noses exposed to view. These precast concrete elements were made as single arched pieces to obtain the required monolithic look.

To meet both architectural and structural objectives, exposed concrete elements consisted of two pieces, installed back to back. Panels were stacked and connected to elements above and below with steel pins. (Typical connection details are shown in Fig. 19.) Note that structural tolerances were applied to architectural shapes, and formed surfaces served as final finishes.



Fig. 10. Erection of the first precast concrete walls. (Courtesy of Don Brown, Metromont Corporation)



Fig. 12. An interior view showing the precast concrete arch in position. (Courtesy of Randy Davis, Design/Build Engineers, Inc.)



Fig. 11. Two cranes hoisting the 77,000 lb (35,000 kg) precast arched spandrels. Note the special rigging with numerous pick points. (Courtesy of Jeff Hargett, Metromont Corporation)



Fig. 13. Stair-stepped column covers were integral to establishing the historic, traditional ambience desired by the owner. (Courtesy of Metromont Corporation)

## TRANSPORTATION AND ERECTION

Shipping and handling of large, heavy precast pieces was a challenge, as these components were manufactured 100 miles (161 km) away from the job site at Metromont's Charlotte, North Carolina, plant. Each piece had

to be shipped by specially permitted and escorted loads on stretch trailers. The pieces were so large, heavy, and awkward to handle that special custom-built slant racks had to be fabricated to legally carry the very heavy loads over Interstate 85 between Charlotte and Taylors, South Carolina.

Erection of the large spandrels re-

quired careful attention to hoisting and rigging methods. The significant weight of the spandrels alone required that the pieces be erected with two cranes (see Fig. 11). Special rigging had to be used for each piece, which included eight pick points on top and four on the back, allowing the spandrels to be safely rolled off the custom-built racks and erected.



## A Multi-Denominational Progression

In 1974, when its only property was a vacant 14-acre parcel in Taylors for a future church site, a growing Catholic congregation met in an Episcopal Church in Greer, South Carolina. When the Church of the Good Shepherd Episcopal Church became too small for the expanding faith community, the Catholic congregation was welcomed in the larger Grace Methodist Church. Later, Lee Road Methodist Church in Taylors offered its sanctuary for the Catholic celebrants on Sundays.

There is a humorous anecdote to this multi-denominational collaboration. In the 1990s, when the pastor, Father Anderson, was planning Prince of Peace's first Seder Feast, he commented during the celebration of mass: "Here I am, a converted Baptist who became a priest, saying a Catholic mass in a Methodist church, and getting ready to celebrate a Jewish feast. I don't think you can get more ecumenical than that!"

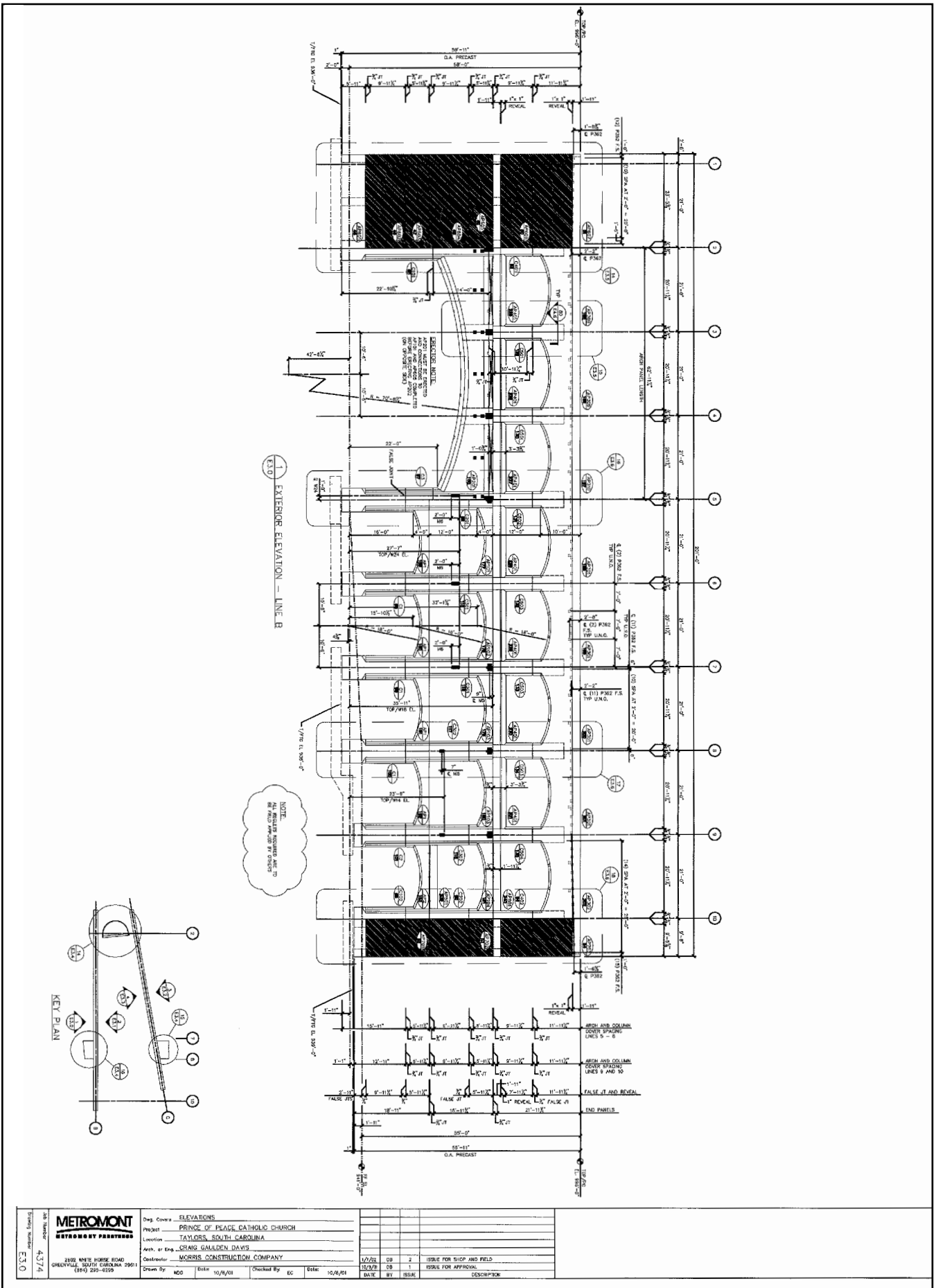

Fig. 14. Exterior elevation. (Courtesy of Metromont Corporation)









Fig. 18. Close-up view of foot of column in the narthex. Precast concrete is particularly effective as a foil to the slate and salt-finished concrete floor. (Courtesy of Brian Dressler)

After placement, smaller loadbearing arches were stacked and aligned on the large arches after all connections were welded and inspected. Both 125 and 90 ton (113 and 82 Mg) cranes were used simultaneously during erection of the larger arched pieces. The skewed walls of the building layout presented further challenges for erection and alignment.

### CONCLUDING REMARKS

The duality of providing the primary interior finish with angled loadbearing panels is the outstanding precast concrete design accomplishment in the new Prince of Peace Church (see Fig. 20). Detailing and surface treatment of the precast concrete panels satisfied aesthetic concerns, while use of the structural panels as the building's primary finish lent integrity to the concept. The precast material is particularly effective as a foil to the brick, stained wood, painted metal, and wallboard surfaces,

blending well with slate and salt-finished concrete floors.

The quality control, sequencing, and redundancy advantages of precast concrete production methods were superior to alternative steel frame and cast-in-place designs that were initially considered for the new church. Rugged and appealing stone finishes created the aesthetic and inspirational qualities desired by the owner. The Prince of Peace Church was dedicated in the fall of 2003.

The Very Reverend Steven L. Brovey, pastor of Prince of Peace Church, underscored the owner's satisfaction with the completed house of worship: "Our parish wanted to achieve a reflection of the Church's millennia-old traditions in a refreshing aesthetic that would speak to a new generation of worshippers. Prince of Peace's precast concrete design is inspirational to the faith community while serving the liturgical functions and religious mission of the Church."

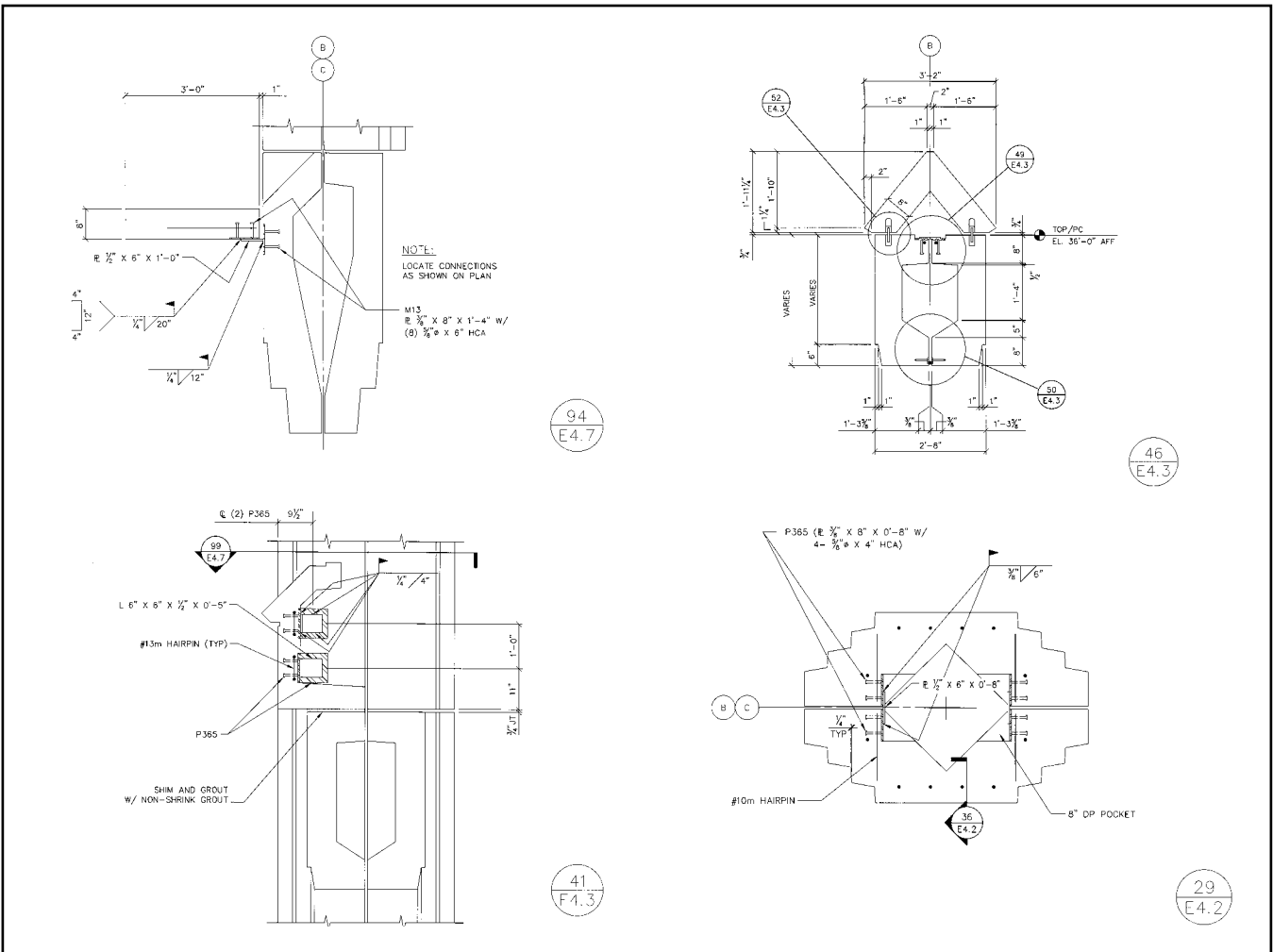

Fig. 19. Connection details. (Courtesy of Randy Davis, Design/Build Engineers, Inc.)



Fig. 20. Taken at night, this photo of the completed Prince of Peace Catholic Church highlights the striking and appealing look of natural stone created with a precast concrete architectural finish. (Courtesy of Brian Dressler)

The Prince of Peace Catholic Church received the 2004 PCI Design Award for Best Precast Custom Solution. “Drawing on the precast concrete walls for its primary inspiration,” the jury remarked, “this design creates a tremendous space for worship and integrates well on its existing campus to the other church elements. It is a tremendous *tour de force* in the use of precast elements in the walls. The precast concrete also transitions between the interior and the exterior and is used well both inside and outside.”

## ACKNOWLEDGMENTS

The authors would like to thank the following individuals for their contributions to the success of the Prince

of Peace project: The Very Reverend Steven L. Brovey, V.F., of the Catholic Diocese of Charleston; Robert Adkins of Design/Build Engineers, Inc., Taylors, South Carolina; and the team from Metromont Corporation of Greenville, South Carolina, including Chuck Gantt, production manager; Troy Lorah and Jim Willis, project managers; Don Brown, drafting coordinator; and Harry Gleich, engineer of record.

The authors would also like to express their appreciation to Davis Erecting, Inc., and transport shipper J. Grady Randolph, both of Greenville, South Carolina. Bill Gowen of Decatur, Georgia, provided great expertise to Metromont in the detailing of the erection and production drawings for

the precast elements, and his contributions are gratefully acknowledged.

## CREDITS

*Owner:* The Catholic Diocese of Charleston (South Carolina)

*Architect of Record:* Craig Gauden & Davis, Inc.; Greenville, South Carolina

*Design Engineer of Record:* Cary Engineering Consultants; Greenville, South Carolina

*General Contractor:* Morris Construction Company, Inc.; Greenville, South Carolina

*Precaster:* Metromont Corporation; Greenville, South Carolina

*Precast Specialty Engineer:* Design/Build Engineers, Inc.; Taylors, South Carolina